



PARTS LIST: 4KRA STATIC READ/WRITE MEMORY

	Item	Quantity
	4KRA printed circuit board	1
IC pack #1:	DM7400N or SN74LS00N	1
	DM74L00N or SN74LS00N <i>2 IC - 011</i>	1
	DM7432N or SN74LS32N	1
	DM8097N or 8T97B	2
	DM8131N	1
	DM8836N	1
	DM8837N	1
MOS IC packs:	AM91L02APC or SYP21L02B	4 packs/ 8 per pack = 32
Bag #1:	6-32x $\frac{1}{2}$ " pan head screws	3
	6-32 hex nuts	3
	#6 lock washers	3
	LM340T-5.0 IC regulator	1
	100 ohm 5% $\frac{1}{4}$ W resistor	2
	2.2K ohm 5% $\frac{1}{4}$ W resistor	2
	solder	
	jumper wire	
Bag #2:	0.1 mfd disk ceramic capacitor	26
	1 mfd 20VDC tantalum electrolytic capacitor	1
	15 mfd 20VDC tantalum electrolytic capacitor	1
Bag #3:	heatsink	1

ASSEMBLY INSTRUCTIONS - 4KRA

MOS Cautionary Information

Care is necessary in the handling of the MOS devices used in this kit. Many MOS devices are sensitive to static electricity and leakage voltages which may be present on ungrounded soldering irons, etc. While most of these devices incorporate internal protection against overvoltage damage, it is important to remember that damage is a possibility. Cotton clothing should be worn rather than synthetics when handling MOS devices. Soldering irons having grounded tips (through a three-wire cord) are preferable. Keep the MOS devices inside their anti-static carriers until ready for use. Static sensitivity decreases after the devices are soldered into a circuit card.

1. Board Orientation: The front surface of the printed circuit card is indicated by the word "FRONT" just above the center of the edge connector fingers. All components will be inserted from this side.
2. TTL Device Loading: Refer to the diagram of component location enclosed, and to the section on "Loading DIP Devices." Insert the following I.C.'s in the following locations:

I.C. type	Location
<input type="checkbox"/> DM74LOON	IC 41
<input type="checkbox"/> DM74109N	IC 40
or DM8214	
<i>(Note: This I.C. is used only in the 4KRA-1 and 4KRA-2 versions. The location is left blank in the 4KRA-4 version.)</i>	
<input type="checkbox"/> DM8836N	IC 39
<input type="checkbox"/> DM8097N	IC 38
<input type="checkbox"/> DM8097N	IC 37
<input type="checkbox"/> DM7432N	IC 36
<input type="checkbox"/> DM7400N	IC 35
<input type="checkbox"/> DM8131N	IC 34
<input type="checkbox"/> DM8837N	IC 33

These locations, and is indicated by a shaded area in the diagram. The location of the component is located at the lower left hand corner of the etched "1" on all locations except 35.

Avoid solder bridges between pins.

All holes are plated through.

Refer to the component location diagram. Positioning the devices so that pin 1 is at the lower left hand corner, insert 9742APC I.C.'s starting at location 1 and proceed across the board to the left. There will be 8, 16, or 32 of these I.C.'s included depending on the kit version.

number of rows filled	number of I.C.'s
1	8
2	16
4	32

Refer to the diagram for component location. Positioning the devices so that pin 1 is at the lower left hand corner, insert 9742APC I.C.'s starting at location 1 and proceed across the board to the left. There will be 8, 16, or 32 of these I.C.'s included depending on the kit version.

Refer to the diagram for component location. Positioning the devices so that pin 1 is at the lower left hand corner, insert 9742APC I.C.'s starting at location 1 and proceed across the board to the left. There will be 8, 16, or 32 of these I.C.'s included depending on the kit version.

3. Solder these I.C.'s to the card, being careful to observe the precautions concerning MOS devices as well as avoiding solder bridges. *NOTE: Solder at the back side of the board only.*

4. MOS device loading: Refer to the component location diagram. Positioning the devices so that pin 1 is at the lower left hand corner, insert 9742APC I.C.'s starting at location 1 and proceed across the board to the left. There will be 8, 16, or 32 of these I.C.'s included depending on the kit version.

kit version	number of I.C.'s
<input type="checkbox"/> 4KRA-1	8
<input type="checkbox"/> 4KRA-2	16
<input type="checkbox"/> 4KRA-4	32

After these I.C.'s have been loaded, solder them to the card, being careful to observe the precautions concerning MOS devices as well as avoiding solder bridges.

5. Disc capacitor loading:
 - Insert 0.1 uf disc ceramic capacitors in the following locations:
 - C1 through C30. Note: position C2 through C30 between the I.C.'s without touching. This requires that the leads be bent as shown in fig. (1). Hold each capacitor in place as it is installed by bending the leads apart. If you can't find C9; there is no C9.
 - Insert C33 through C42 in their proper positions.
 - Solder the leads of all the capacitors and trim the excess lead lengths as close to the board as possible.

6. Tantalum capacitor installation:

- () Install 1.0 uf, 20 volt tantalum capacitors C31 and C32 as shown on the component location diagram. The positive lead of these capacitors, as indicated by a "+" on the body of the capacitor, is connected to the printed circuit traces on the top side of the board.
- () Bend the leads outwards underneath the board and solder. Trim the leads as close to the board as possible.
- () Install the 15 uf, 20 volt tantalum capacitor C43 in the location shown in the component location diagram. The positive lead connects to the printed circuit trace on the bottom side of the card, through the hole which has a square area around it on the top side.
- () Bend and solder the leads to this capacitor as above. Trim the leads as close to the board as possible.

fig. 1 - lead formation,

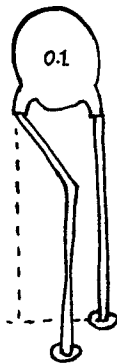

capacitors C2-C8, C10-C30

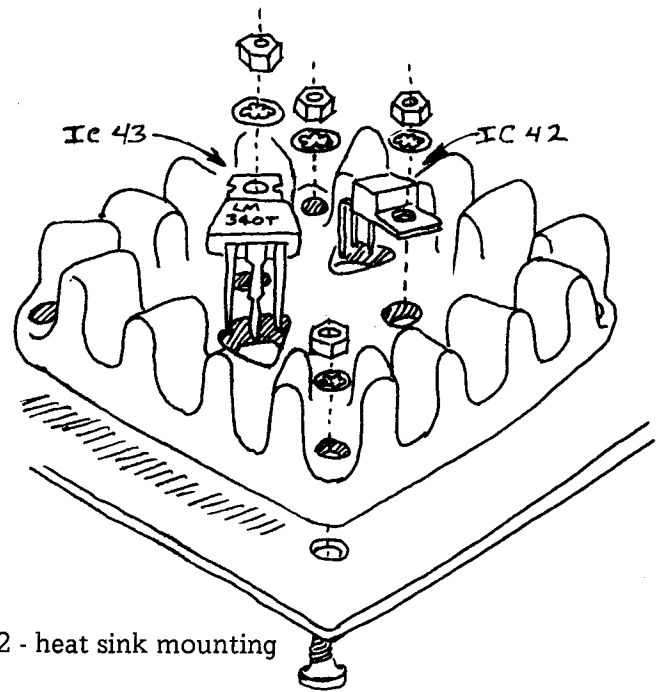

fig. 2 - heat sink mounting

7. Resistor Installation: Referring to the component location diagram, install resistors R1 through R4 as follows:

	resistor value	color code	location
() ()	2,200 ohms	red-red-red-gold	R1, R2
() ()	100 ohms	brown-black-brown-gold	R3, R4
()	Solder and trim leads.		

8. Heat Sink Installation:

- () Install the black, finned heat sink on the top side of the card, flat face down, with all holes lined up. Secure the heat sink to the card with the two 6-32 machine screws, using lockwashers underneath the nuts. Install the screws with their heads on the underside of the card. Do not tighten screws completely until regulator I.C.'s are installed.

9. Regulator Installation: Refer to Fig. 2. Position I.C.'s 43 and 42 (LM340T-5.0) over their mounting locations on the heat sink and observe how the leads must be bent to engage their holes on the card. The center lead must be bent at a point approximately 0.2 inches further away from the body of the regulator. Use of silicone heatsink compound is recommended between the regulator I.C.'s and the heatsink.

- () Bend the leads and adjust them, if necessary, so that the regulators may be mounted to the heat sink *without the leads touching the heat sink*.
- () Secure the regulators with 6-32 machine screws, using lockwashers under the nuts. Insert the screws from the bottom side of the card.
- () Solder the leads of the regulators and clip the excess off as close to the card as possible.

10. () Install Augat receptacle pins in address-select holes as follows:
- () Wedge the board between two objects so that it stands slightly off vertical with the top side up.
 - () The Augat receptacle pins are mounted on a DIP-style metal carrier. Pull off one pin and insert it from the top side of the board into one of the address-selection holes. The fit will be loose.
 - () Carefully solder the pin to the pad. The pin will end up out of perpendicular to the board.
 - () Insert a component lead into the receptacle. Reheat the solder and, using the component lead, adjust the position of the receptacle until it is more nearly perpendicular to the board. Allow the solder to solidify while holding the pin as steady as possible. A mottled or crystallized solder joint indicates a "cold joint" and should be reheated.
 - () When all the pins have been installed, check carefully for cold joints or solder bridges.

4KRA — OPERATING RESTRICTIONS

1. Take care not to attach clip leads to the top edge of the card when the unit is powered. This will short the +8 volt bus to ground.
2. Due to regulator current limitations, no more than 8 additional standard 2102 - type RAM chips may be installed on a -1 or -2 versions. Low power units, available from Processor Technology, are necessary for operation of a full card (4K).
3. If RAM chips with worst case access times of greater than 500 nsec and less than 1.0 microsecond are used, the board must be strapped for one waiting state.
If RAM chips with worst case access times of 1.0 to 1.5 microseconds are used, the board must be strapped for two waiting states.

4KRA ADDRESS RANGE SELECTION

The starting address of the 4KRA is selected by the connection of four jumpers at the lower right-hand corner of the board. Each of the four round pads on the upper row has two oval pads below it. The left-hand pad of the pair on the bottom row is connected to a trace on the top side of the card. This set of pads will be designated H. The other set of pads, which connect to the ground trace on the bottom side of the board, will be designated L. (See fig. 4).

Using short lengths of bare wire, #24 or 26, make the connections as indicated in the chart below. Only the indicated addresses are available for starting addresses; no intermediate addresses may be used.

Starting Address

Decimal	Octal	A15	A14	A13	A12
0	0	L	L	L	L
4,096	10,000	L	L	L	H
8,192	20,000	L	L	H	L
12,288	30,000	L	L	H	H
16,384	40,000	L	H	L	L
20,480	50,000	L	H	L	H
24,576	60,000	L	H	H	L
28,672	70,000	L	H	H	H
32,768	100,000	H	L	L	L
36,864	110,000	H	L	L	H
40,960	120,000	H	L	H	L
45,056	130,000	H	L	H	H
49,152	140,000	H	H	L	L
53,248	150,000	H	H	L	H
57,344	160,000	H	H	H	L
61,440	170,000	H	H	H	H

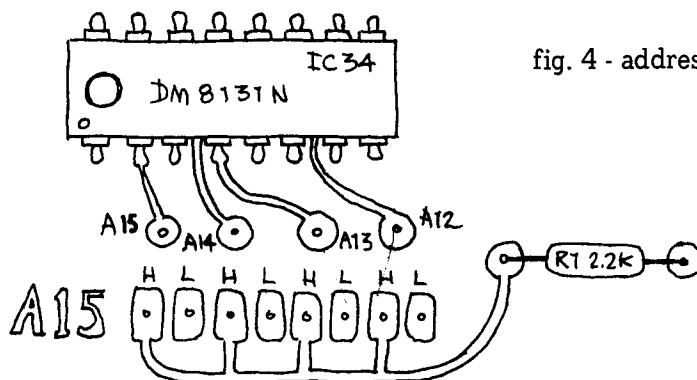

fig. 4 - address selection jumpers

WAIT STATE SELECTION (See fig. 3)

Since the RAM chips shipped by Processor Technology are specified for operation at 500 nanoseconds, no waiting time is required. The circuit is set up for this condition by connecting a jumper wire between the "W" pad above I.C.39 and the "N" pad to its left just next to the 2.2K resistor.

If slower RAM chips are installed in a -1 or -2 card, the waiting time may have to be enabled. To do this, the jumper is removed from "N" to "W", and a jumper is installed from "Y" to "W". The number of wait states, each .5 micro-second, is determined by the numbered pad (2 or 1) connected to the "W" pad below the I.C. 40. If waiting time is enabled, one of these must be connected.

W = wait
N = no
Y = yes

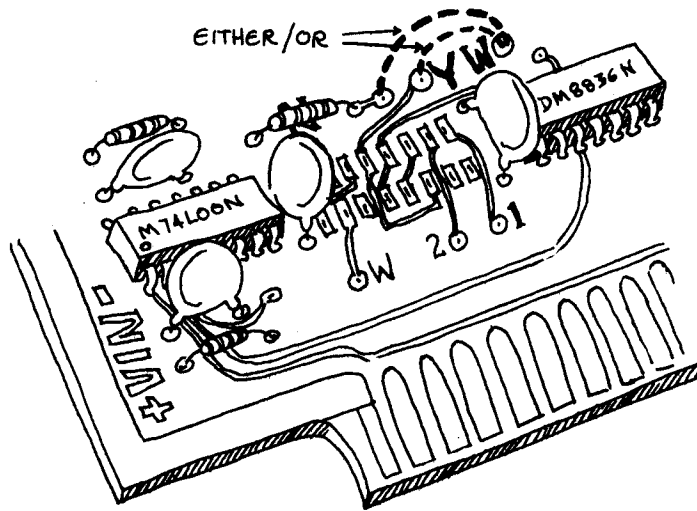

fig. 3 - optional wait state jumpers

- > connect from "W" to "N" for normal operation
- > connect from "W" to "Y" for wait states (IC 40 must be installed)